

Features

- Supports the SensL ArrayJ-30035-64P-PCB
8x8 array of 3mm SiPMs
- “HB” variant: Horizontal signal connector located on the back, array located on the front
- Row-and-column position encoding for event centroid calculations
 - DC-coupled signal path
 - Low power consumption
- Patented diode-coupled charge division readout, superior to traditional resistive readout
 - Improved spatial uniformity
 - Faster rise time
 - Reduced image noise
- Precision temperature sensor
- Mounting holes for #4 or M3 hardware
- SensL’s fast output signals are not connected

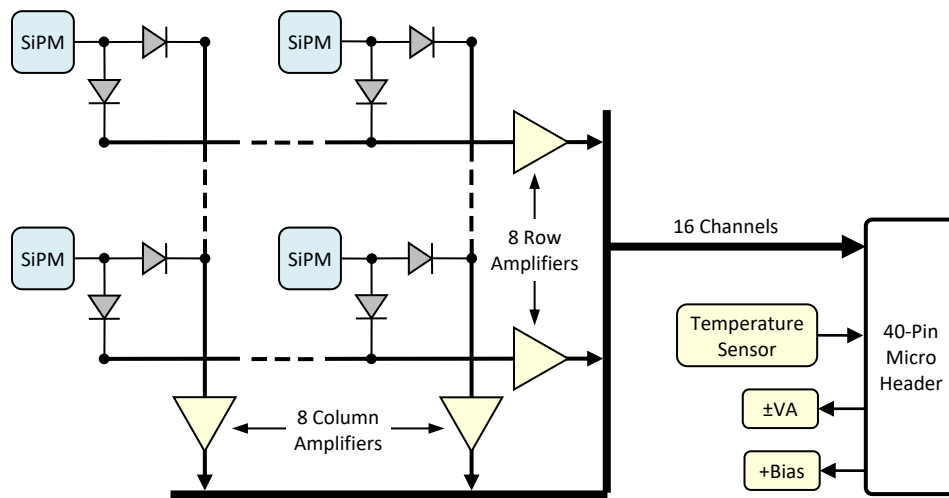
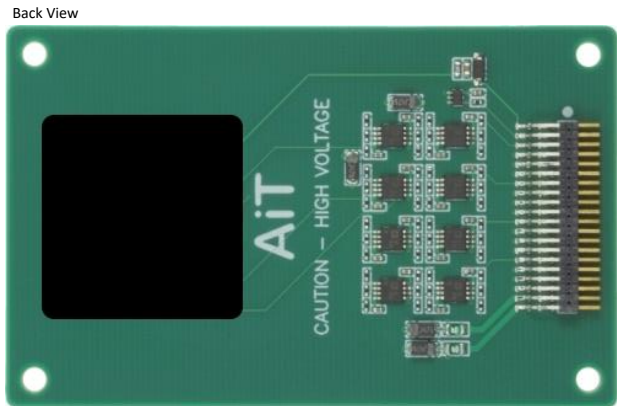
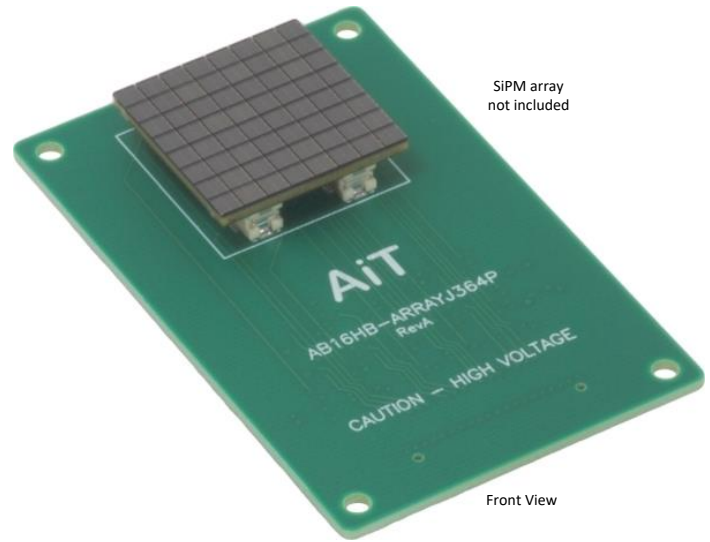

Specifications

SiPM Signal Amplifiers

Encoding	Charge division multiplexed to 8 rows and 8 columns
Gain	750Ω transimpedance gain
Output voltage	0 → -1V into 100Ω
Output impedance	100Ω
Output current	50mA maximum

Temperature Sensor

Output voltage	500mV + 10mV per °C
Output current	10mA
Output impedance	100Ω
Accuracy	±0.5°C

Bias Voltage

	+29V typical (refer to SiPM data)
Voltage clamp	47V Zener diode 500mW maximum

Amplifier Power (±VA)

Current	±30mA typical (I _q , no signal, no load)
---------	--

Signal Connector

	Horizontal 40-pin 2-row header with 0.050" pin pitch
Mating assembly	Samtec FFSD-20-D-XX.XX-01-N (XX.XX = length in inches)

Channel Map

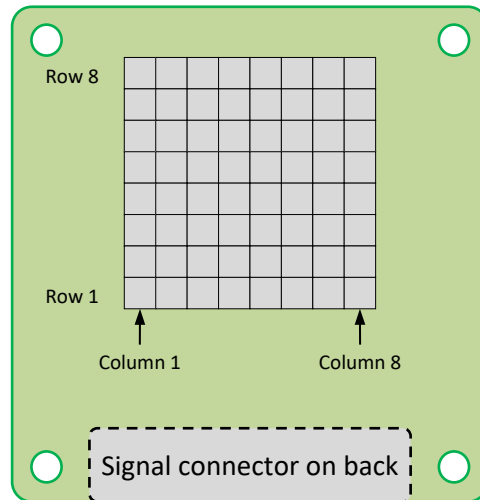

Front view

Signal Connector

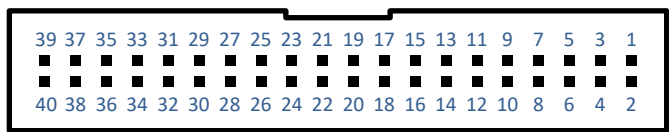

40-pin 0.050" horizontal header

Pin	Function	Pin	Function
1	Bias	2	Ground
3	Temperature	4	Ground
5	Row 1	6	Ground
7	Row 2	8	Ground
9	Row 3	10	Ground
11	Row 4	12	Ground
13	Row 5	14	Ground
15	Row 6	16	Ground
17	Row 7	18	Ground
19	Row 8	20	Ground
21	Column 1	22	Ground
23	Column 2	24	Ground
25	Column 3	26	Ground
27	Column 4	28	Ground
29	Column 5	30	Ground
31	Column 6	32	Ground
33	Column 7	34	Ground
35	Column 8	36	Ground
37	-VA	38	Ground
39	+VA	40	Ground

Typical Signals

Source = Laser; Receiver = ABR16, channel 4, minimum gain; Bias = +28V; FFSD cable = 12"

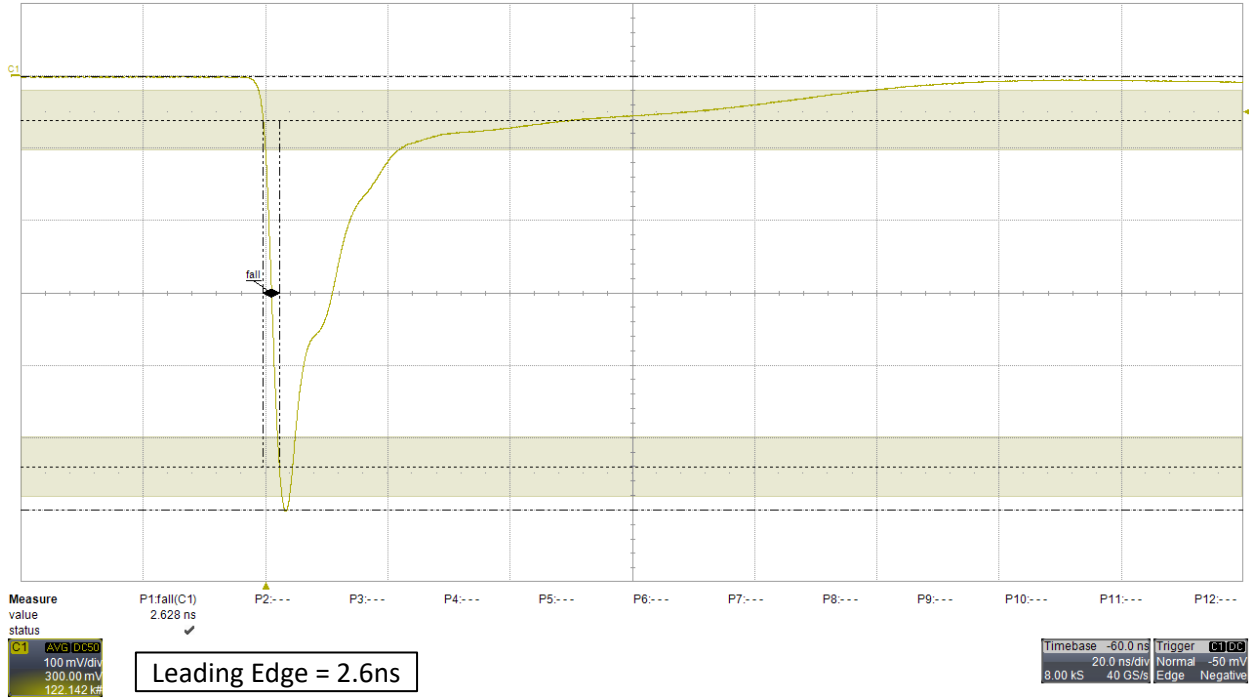

Source = LYSO emission; Receiver = ABR16, channel 4, minimum gain; Bias = +28V; FFSD cable = 12"; persistence display

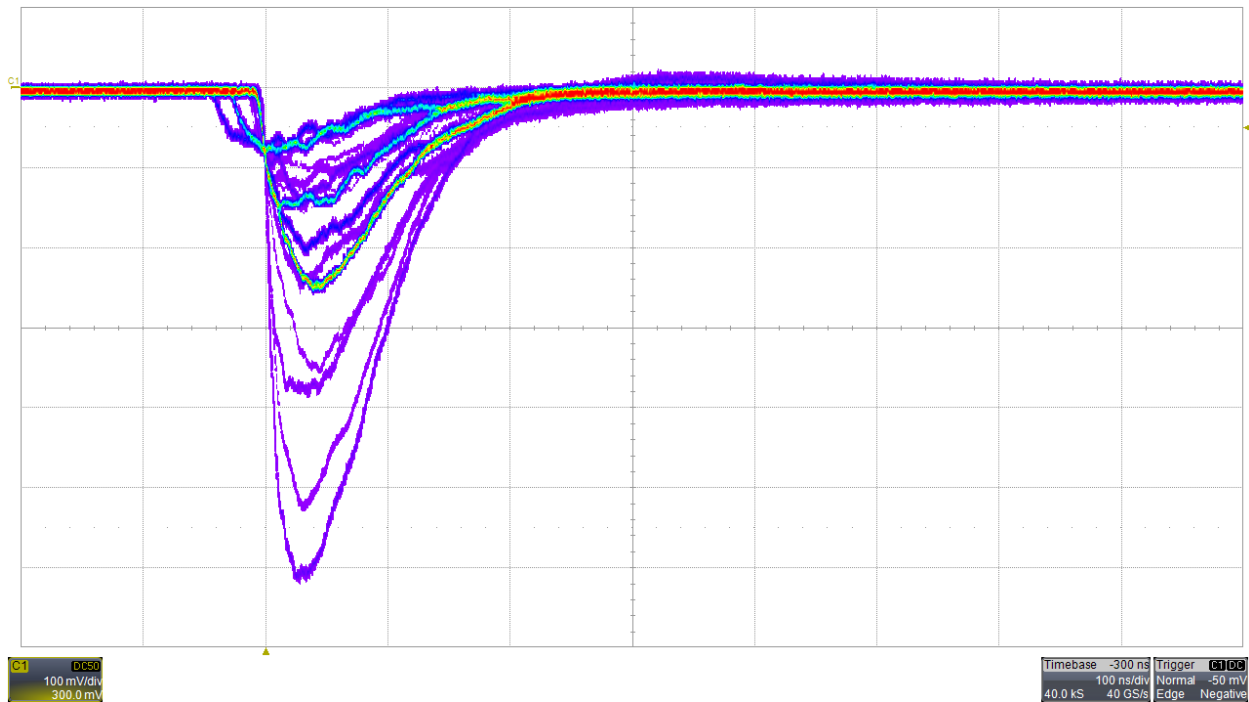

Mechanical

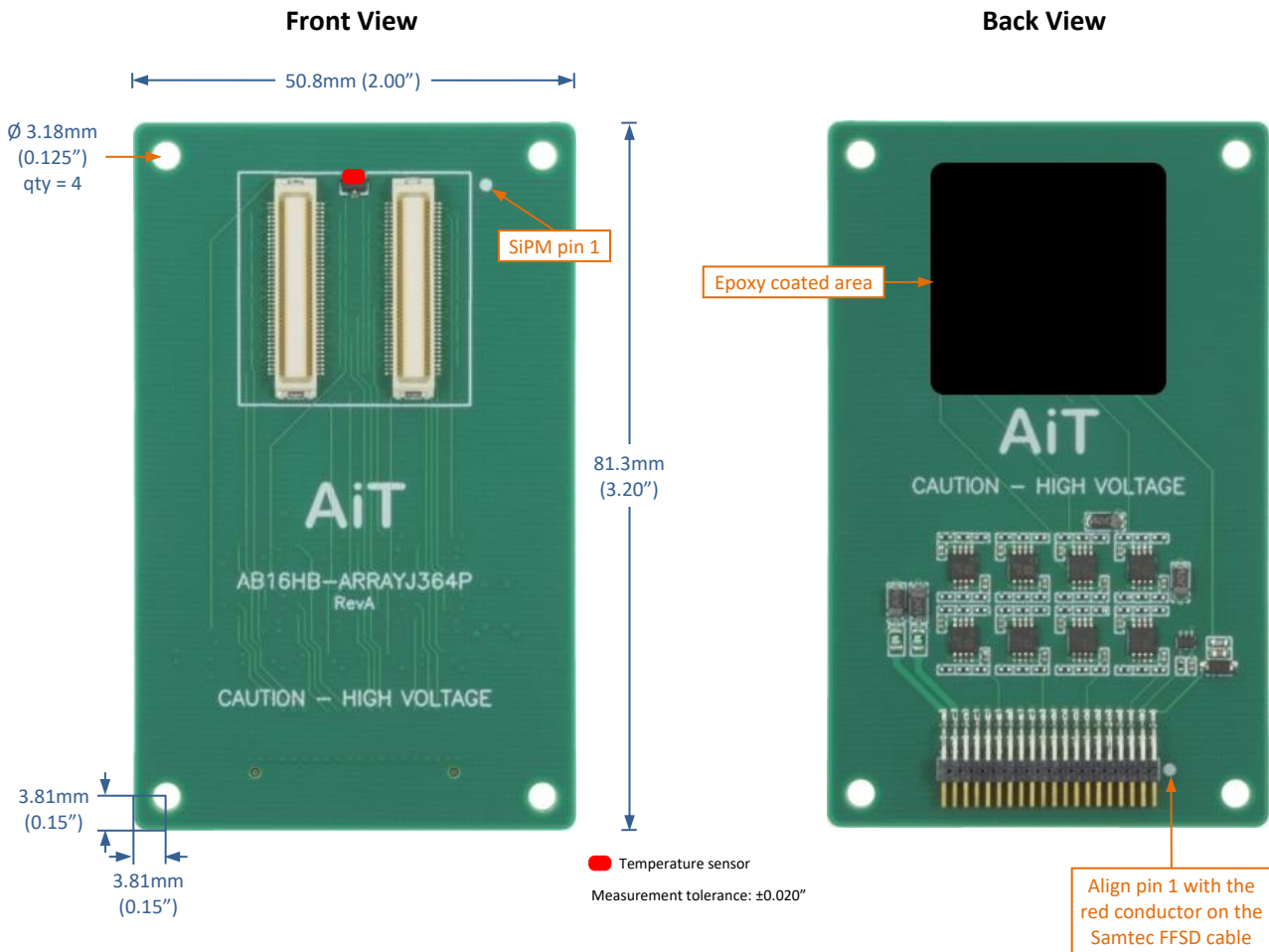

Array Location

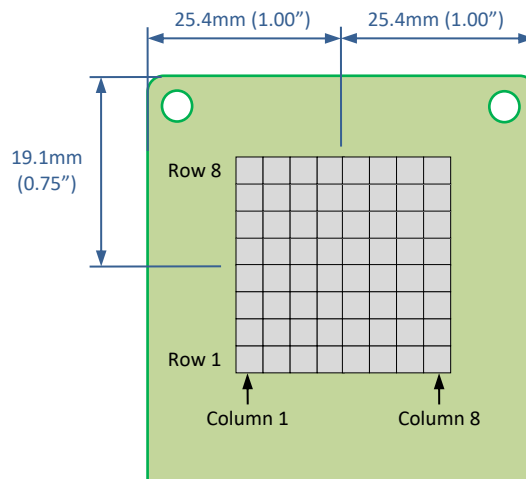

16-Channel Active Base Readout Kit

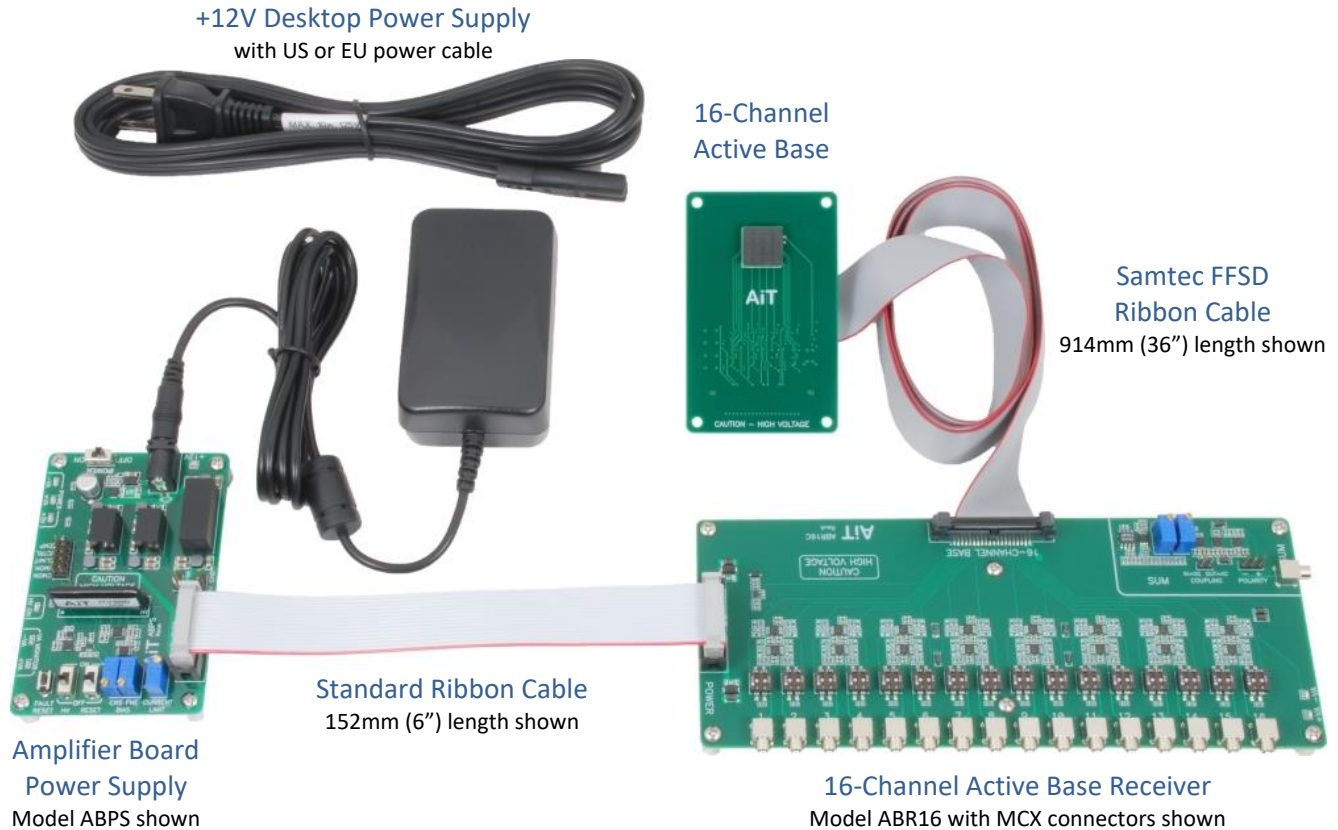

Components

Each component is available separately. Refer to each datasheet for details.

The Active Base includes a 914mm (36") Samtec FFSD micro-pitch ribbon cable.

The Amplifier Board Power Supply includes a 12V desktop power supply and a HV80 bias voltage power supply.

The 16-channel Active Base Receiver includes a 152mm (6") power supply ribbon cable and a breakout board to connect any external power supply.

Safety Information



WARNING – High Voltage

- High voltage may be present during operation
- High voltage stored on capacitors may be present after power is removed
- Improper handling may result in personnel injury or equipment damage

This high-voltage device must be used only by personnel trained and qualified in safe handling, installation, and operation of high-voltage equipment.



CAUTION – Electrostatic Discharge (ESD) Sensitivity

The circuit board can be damaged by electrostatic discharge. Observe precautions for handling electrostatic sensitive devices. Handle only at static-safe workstations.

High-Gain Photodetectors

High-gain photodetectors such as silicon photomultipliers may conduct damaging currents if exposed to high optical signal levels while the bias voltage is applied, or if the bias voltage exceeds the recommended operating range. These devices must be operated only in low-light conditions, and only within the manufacturer's recommended bias voltage range.

Handling and Disassembly

This product may be provided with a protective enclosure. Disassembled enclosure components and circuit boards may contain sharp edges. Take appropriate safety precautions while assembling or disassembling the enclosure and handling disassembled components.

Indoor Use Only

Do not operate this product in a wet or damp environment. Do not operate in an explosive atmosphere.

Use of this product, and AiT Instruments' liability related to use of this product, is further governed by AiT Instruments' standard terms and conditions of sale, which were provided upon purchase of this product.