

**Features**

- Connects to one AiT 16-channel SiPM Passive Base
- 1-stage wideband DC-coupled amplifier per channel
  - 1.8ns minimum rise time
  - Transimpedance amplifier option (500Ω gain)
  - Voltage amplifier option (50Ω shunt, x10 gain)
  - Contact us for customization
- Sum of 16 SiPM signals for triggering
  - Gain adjustment potentiometer
  - Offset adjustment potentiometer
  - DC or AC coupling selection jumper
  - Polarity selection jumper

**Standard Accessories**

- 40-conductor Samtec FFSD ribbon cable assembly, 152.4mm (6") length standard
- 16-conductor standard ribbon cable assembly, 152.4mm (6") length standard
- Power supply breakout board
- Six threaded standoffs with #4-40 screws

**Part Number**

PBA116 {V/T} {connector} - Lxx  
 {V/C}: V = Voltage amplifier  
           T = Transimpedance amplifier  
 {connector}: Output connector type  
               M=MCX, A=SMA, B=SMB, L=LEMO  
 Lxx: xx is the FFSD cable length in inches  
Example: PBA116TM-L6  
           Transimpedance amplifier,  
           MCX connectors, 6" cable

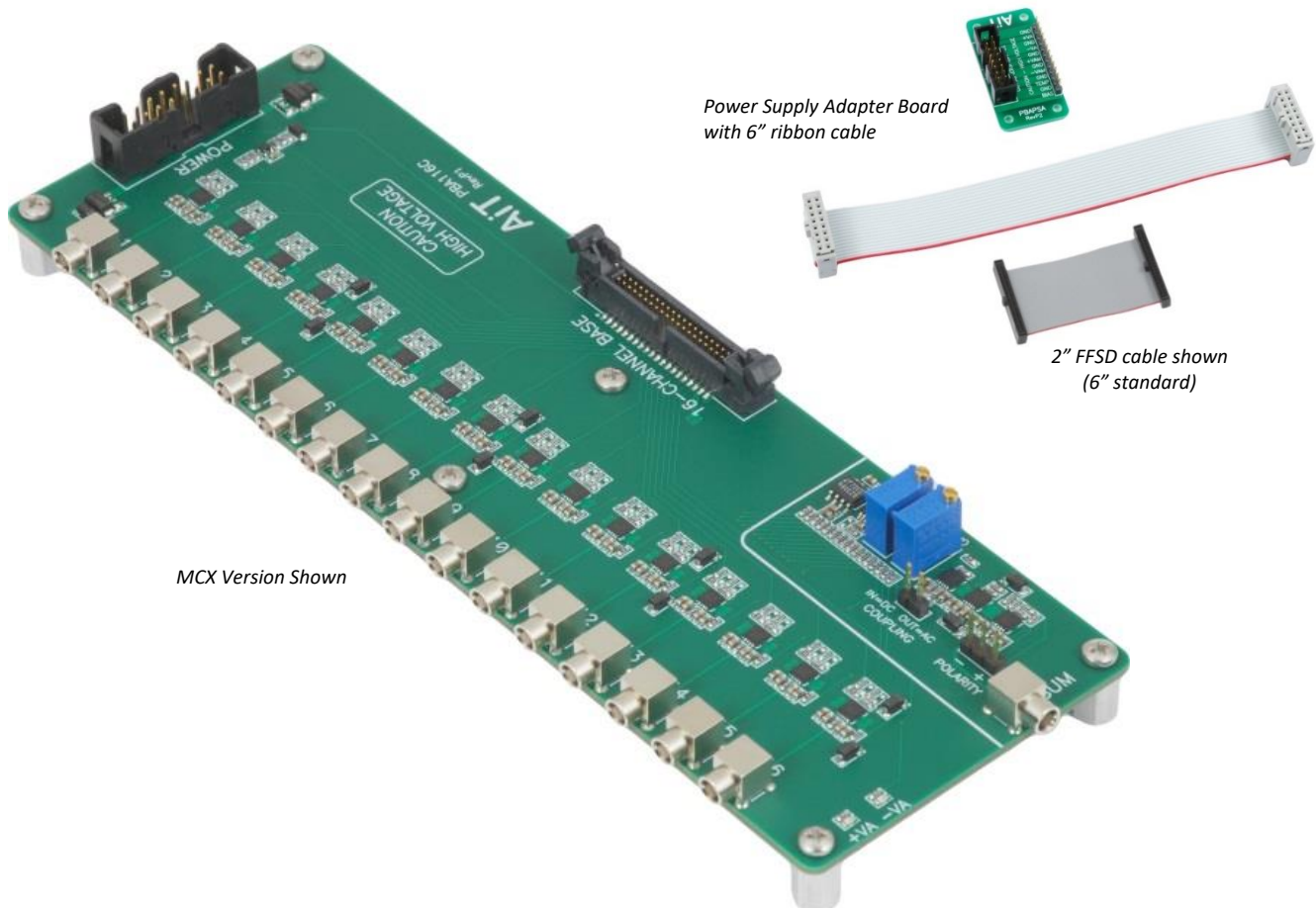

MCX Version Shown

Power Supply Adapter Board with 6" ribbon cable

2" FFSD cable shown (6" standard)

## 16-Channel Passive Base Readout Kit

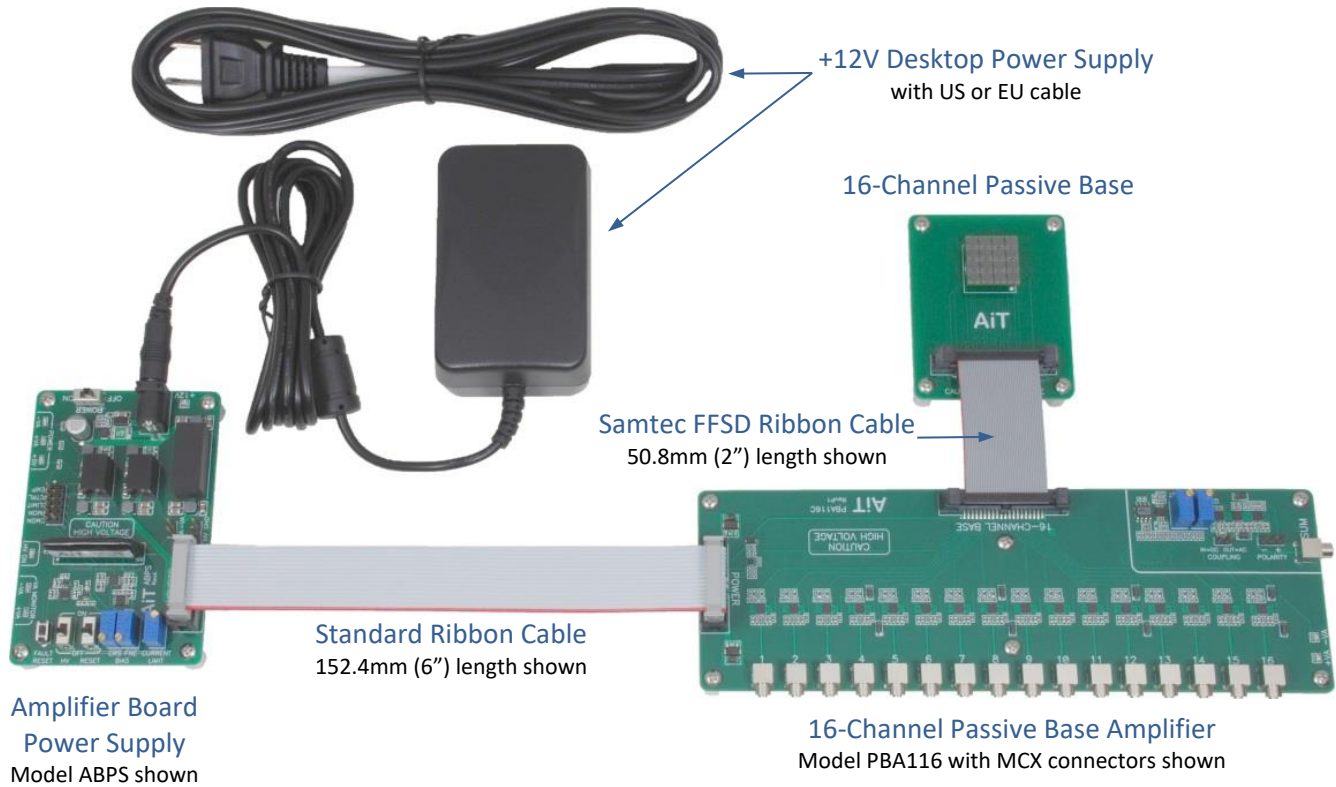

### Components

Each component is available separately. Refer to each datasheet for details.

No accessories are included with the Passive Base.

The Amplifier Board Power Supply includes a 12V desktop power supply and a HV80 bias voltage power supply.

The 16-channel Passive Base Amplifier includes a 152.4mm (6") FFSD cable to connect the passive base, a 152mm (6") power supply ribbon cable, and a breakout board to connect any external power supply. For fast rise times, a 50.8mm (2") FFSD cable is recommended.

**Architecture**

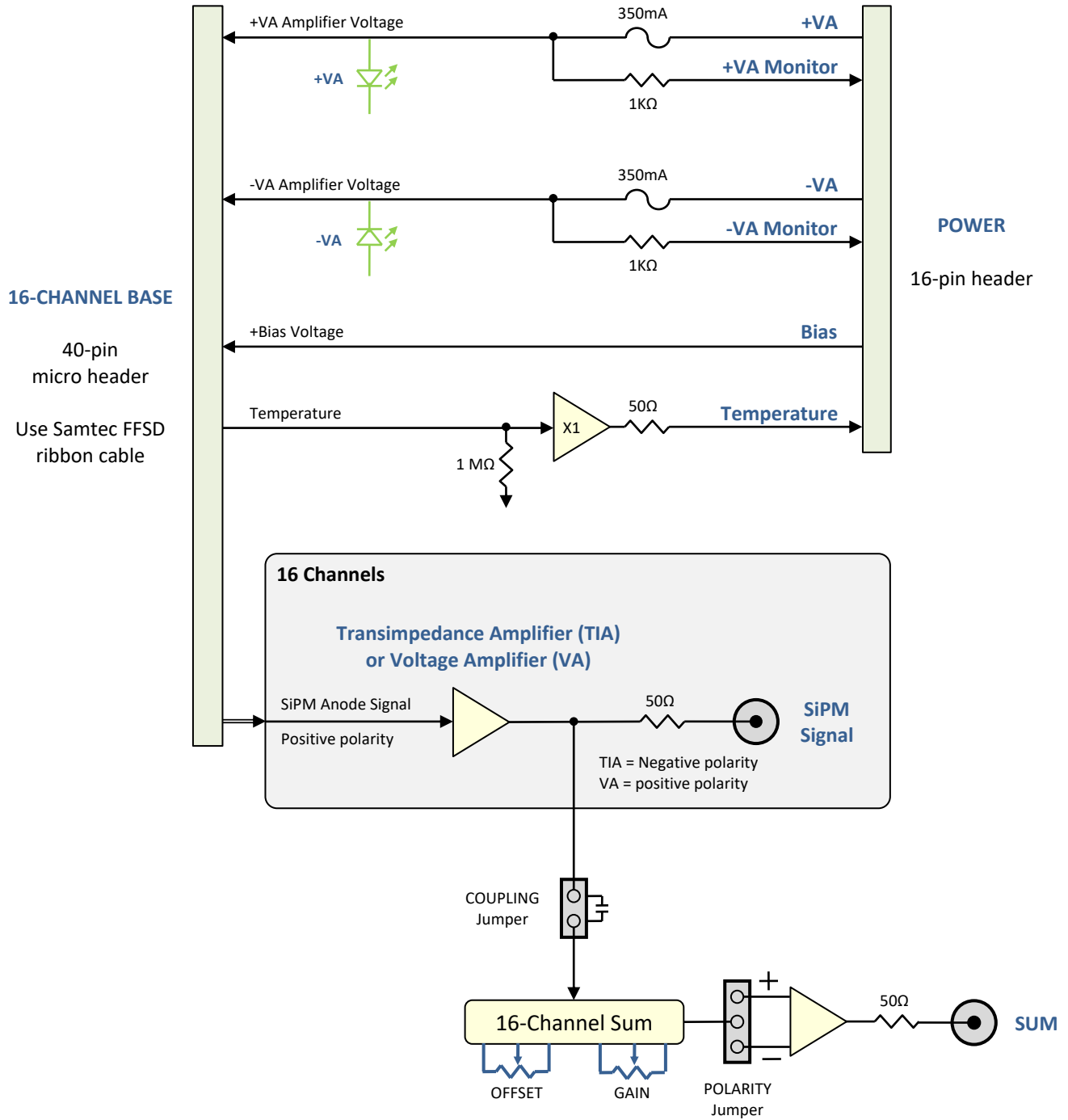

## Specifications

Test conditions:  $V_A = \pm 5.0V$

<b>Amplifier Voltage</b>	$\pm 2.5V \rightarrow \pm 5.5V$ DC
Current	$\pm 270mA$ at $\pm 5.0V$ ( $I_q$ , no base, no load)
Protection	350mA resettable fuses $\pm 5.6V$ Zener diode clamp Reverse voltage protection
<b>Bias Voltage</b>	
Voltage clamp	+82V Zener diode 375mW maximum
Caution	This device does not limit bias current
<b>Transimpedance Amplifier Option</b>	
Input rise time	1.8ns minimum $\geq 5.0ns$ recommended Performance depends on SiPM technology and signal source. Refer to Passive Base datasheets for performance of specific SiPMs.
Output rise time	1.8ns minimum
Gain	500 $\Omega$ transimpedance gain standard Contact us for different gains
Input polarity	Bipolar capable, normally positive
Coupling	DC
Output polarity	Bipolar capable, normally negative
Output voltage range	$\pm 3.4V$ maximum ( $\pm 1.7V$ into 50 $\Omega$ ) with $V_A = \pm 5.0v$
Output current	100mA maximum
Output impedance	50 $\Omega$
<b>Voltage Amplifier Option</b>	
Input rise time	1.8ns minimum $\geq 5.0ns$ recommended Performance depends on SiPM technology and signal source. Refer to Passive Base datasheets for performance of specific SiPMs.
Output rise time	1.8ns minimum
Gain	x10 standard Contact us for different gains
Input impedance	50 $\Omega$ Contact us for different impedances
Input polarity	Bipolar capable, normally positive
Coupling	DC
Output polarity	Bipolar capable, normally positive
Output voltage range	$\pm 3.4V$ maximum ( $\pm 1.7V$ into 50 $\Omega$ ) with $V_A = \pm 5.0v$

Output current 100mA maximum

Output impedance 50Ω

**Signal Sum**

Minimum output rise time 1.8ns

Output polarity Positive or negative, jumper selectable

Gain adjustment x0 → x2, referred to one output channel at channel gain = 1  
25-turn potentiometer

Input offset adjustment ±250mV at sum gain = 1  
25-turn potentiometer  
Sum gain adjusted to match channel output at channel gain = 1

Coupling AC or DC, jumper selectable

AC coupling time constant 1.9μs

Output voltage range ±3.4V maximum (±1.7V into 50Ω) with VA = ±5.0v

Output current ±100mA maximum

Output impedance 50Ω

**Channel-to-Channel Timing**

Signal length between output channels 500ps maximum skew  
Channels 1 to 8 are symmetrical to channels 16 to 9  
Minimum skew is between channels 1 and 16, 2 and 15, ..., 7 and 8  
Maximum skew is between channels 1 and 7, 8 and 16

Signal length between output and sum 500ps maximum skew  
Minimum for channel 16 and maximum for channel 1  
Minimum skew is between adjacent channels  
Maximum skew is between channels 1 and 16

**Passive Base Cable Length**

Recommended lengths 50.8mm (2") recommended for most applications.  
Up to 304.8mm (12") can be used for slower signals.  
Cable lengths exceeding 304.8mm (12") have not been tested.

Excessive cable lengths Long cables can be used if the application can tolerate increased signal distortion.  
Signal distortion depends on signal edge speed, cable length, SiPM technology, and channel. Slower signals can be transmitted over longer cables with less distortion.

Note Refer to individual AiT Passive Base datasheets for measurements

**Temperature Monitor Buffer**

Input voltage +3.0V maximum

Output voltage +3.0V maximum

Output current 10mA maximum

Input impedance 1MΩ

Output impedance 50Ω

**LEDs**

+VA	Green = Positive amplifier voltage
-VA	Green = Negative amplifier voltage

**Connectors**

16-CHANNEL BASE	Vertical 40-pin, 2-row latch-eject header, 0.050 inch pin pitch Mating assembly = Samtec FFSD-20-D-XX.XX-01-N (XX.XX = length in inches)
POWER	Vertical 16-pin shrouded header, 0.100" pin pitch

## Connectors

### 16-CHANNEL BASE

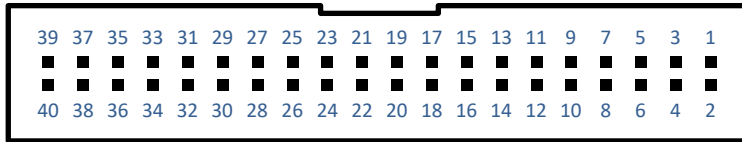

40-pin 0.050" vertical latch-eject header

Pin	Function	Pin	Function
1	Bias	2	Ground
3	Temperature	4	Ground
5	Anode 1	6	Ground
7	Anode 2	8	Ground
9	Anode 3	10	Ground
11	Anode 4	12	Ground
13	Anode 5	14	Ground
15	Anode 6	16	Ground
17	Anode 7	18	Ground
19	Anode 8	20	Ground
21	Anode 9	22	Ground
23	Anode 10	24	Ground
25	Anode 11	26	Ground
27	Anode 12	28	Ground
29	Anode 13	30	Ground
31	Anode 14	32	Ground
33	Anode 15	34	Ground
35	Anode 16	36	Ground
37	-VA	38	Ground
39	+VA	40	Ground

### POWER

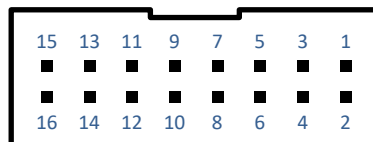

16-pin 0.100" vertical header

Pin	Function	Pin	Function
1	+VA	2	+VA
3	Ground	4	Ground
5	-VA	6	-VA
7	Ground	8	Ground
9	+VA Monitor	10	Ground
11	-VA Monitor	12	Ground
13	Temperature	14	Ground
15	Bias	16	Ground

**Mechanical**

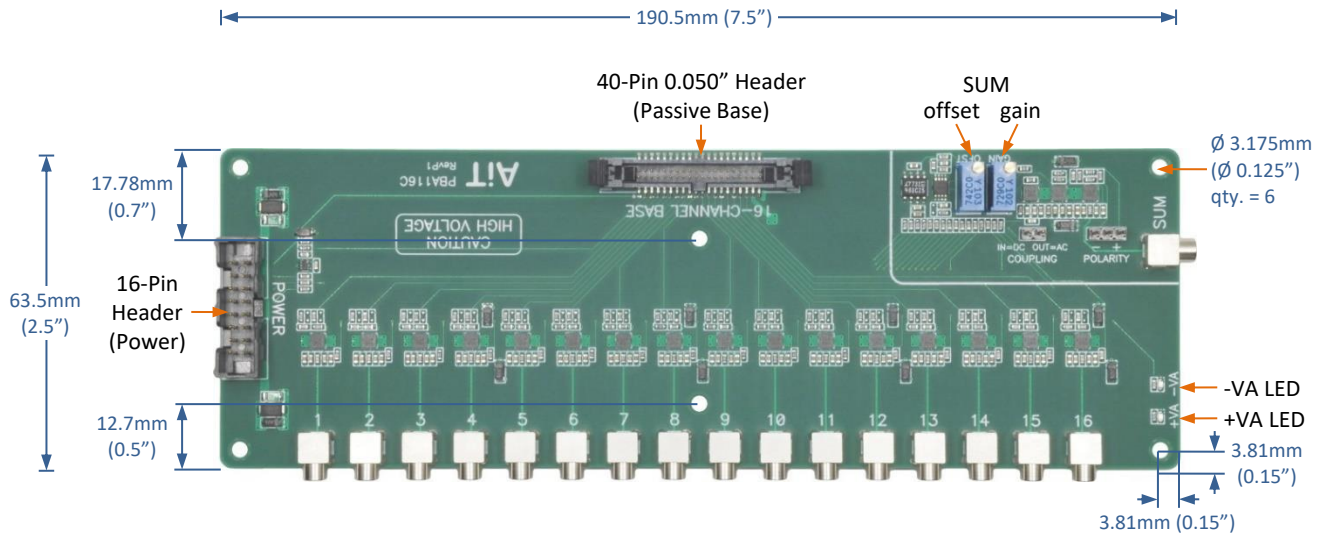

**Jumpers**

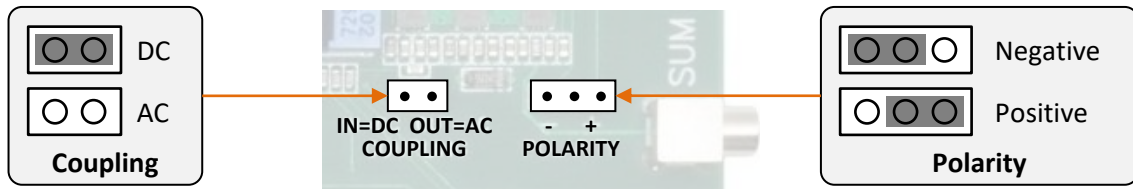



## Operation

### Typical Setup Procedure

1. Make sure the Amplifier Board bias voltage and amplifier voltage are off  
Always handle the amplifier and base with bias voltage and amplifier voltage OFF
2. Configure the gain jumpers, sum coupling jumper, and sum polarity jumper  
DC coupling is recommended for most applications
3. Connect the Base
4. Connect an oscilloscope to the SUM output and one or more SiPM signals
5. Apply power to the Amplifier Board
6. With SiPM signals present, adjust the bias voltage, *SUM Offset*, and *SUM Gain* as needed
  - a. Adjust the SiPM bias voltage until SiPM signals are present
  - b. Adjust the *SUM Offset* until the SUM signal baseline is zero
  - c. Adjust the *SUM Gain* to the desired level
7. Changes in bias voltage may require offset adjustment

### Sum Coupling Jumper

DC coupling is selected when the jumper is installed. DC coupling is recommended for high-rate signals. AC coupling is selected when the jumper is removed. AC coupling is recommended for low-rate signals.

### Sum Polarity Jumper

Placing the jumper in the “- / center” (negative) position will select the same polarity as the preamplified SiPM output signals. Placing the jumper in the “+ / center” (positive) position will select the inverted polarity. A standard Passive Base produces positive output signal polarity. The polarity is inverted by the input transimpedance amplifiers. A negative sum signal polarity is selected by placing the jumper in the negative position.

## System Assembly Guidelines

### Passive Base FFSD Cable

The Samtec micro-pitch FFSD cable connector must be inserted firmly into the header. During insertion, the header latches will clamp over the edges of the cable connector body and hold it firmly in place. The cable is oriented correctly when the cable exits directly away from the Amplifier Board without interference, and the red index conductor is located on the right side of the FFSD header when facing the header.

### High Voltage

This device must be used only by personnel trained and qualified in safe handling, installation, and operation of high voltage equipment. Any optional enclosure provided does not protect against high voltage exposure.

During operation, high voltage will normally be present in the following components:

- Amplifier board, especially the POWER connector and the SiPM BASE connector
- SiPM base signal cable
- SiPM base

**Caution:** This device does not limit bias current. Take precautions to limit bias current to prevent equipment damage and personnel injury.

### Installation

This device is intended for benchtop usage, or incorporated into another system or product. The circuit board may be installed using standard #4 or M3 hardware. Allow for adequate ventilation space around the circuit board.

## Safety Information



### **WARNING – High Voltage**

- High voltage may be present during operation
- High voltage stored on capacitors may be present after power is removed
- Improper handling may result in personnel injury or equipment damage

This high-voltage device must be used only by personnel trained and qualified in safe handling, installation, and operation of high-voltage equipment.



### **CAUTION – Electrostatic Discharge (ESD) Sensitivity**

The circuit board can be damaged by electrostatic discharge. Observe precautions for handling electrostatic sensitive devices. Handle only at static-safe workstations.

## High-Gain Photodetectors

High-gain photodetectors such as silicon photomultipliers may conduct damaging currents if exposed to high optical signal levels while the bias voltage is applied, or if the bias voltage exceeds the recommended operating range. These devices must be operated only in low-light conditions, and only within the manufacturer's recommended bias voltage range.

## Handling and Disassembly

This product may be provided with a protective enclosure. Disassembled enclosure components and circuit boards may contain sharp edges. Take appropriate safety precautions while assembling or disassembling the enclosure and handling disassembled components.

## Indoor Use Only

Do not operate this product in a wet or damp environment. Do not operate in an explosive atmosphere.

Use of this product, and AiT Instruments' liability related to use of this product, is further governed by AiT Instruments' standard terms and conditions of sale, which were provided upon purchase of this product.