

Features

Supports a 2x2 arrangement of Onsemi ArrayJ-30035-64P-PCB 8x8 SiPM arrays for a total of 16x16 SiPMs

Horizontal connectors located on the back, arrays located on the front

4-side tileable installation

Row-and-column position encoding for event centroid calculations

DC-coupled signal path

Low power consumption

Patented diode-coupled charge division readout, superior to traditional resistive readout

Improved spatial uniformity

Faster rise time

Reduced image noise

Precision temperature sensor

Fast output signals are not connected

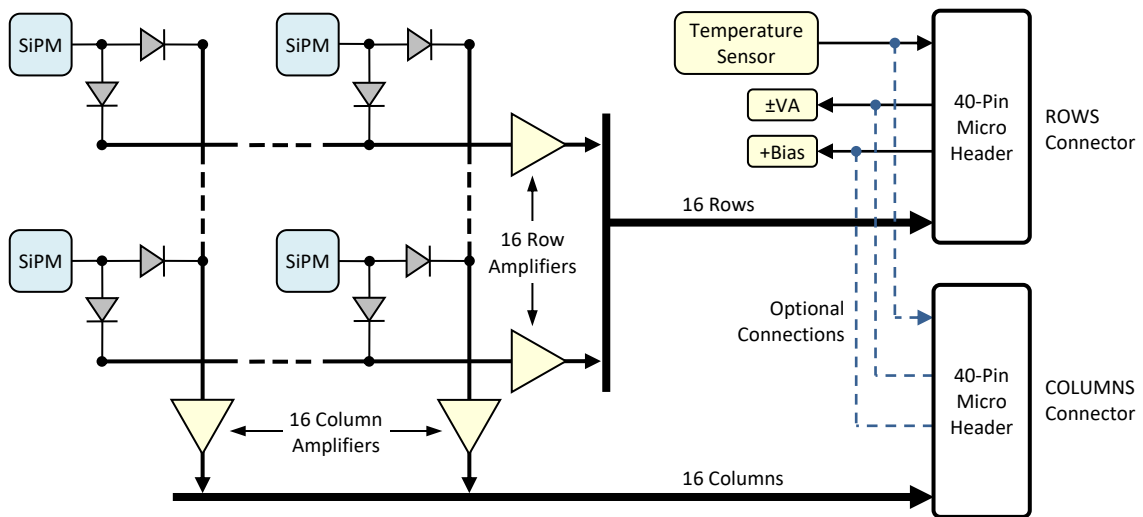
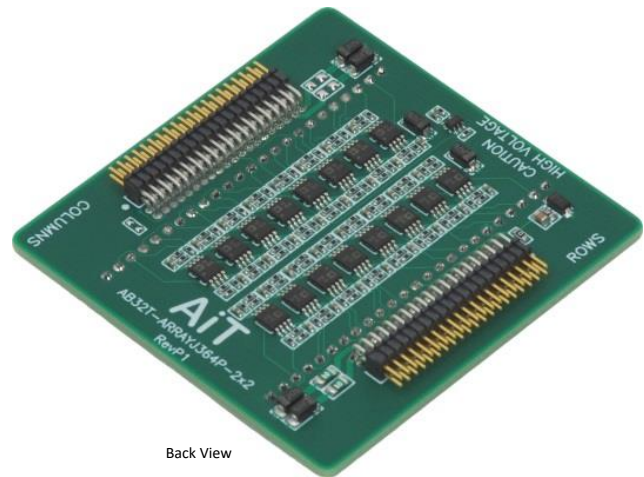
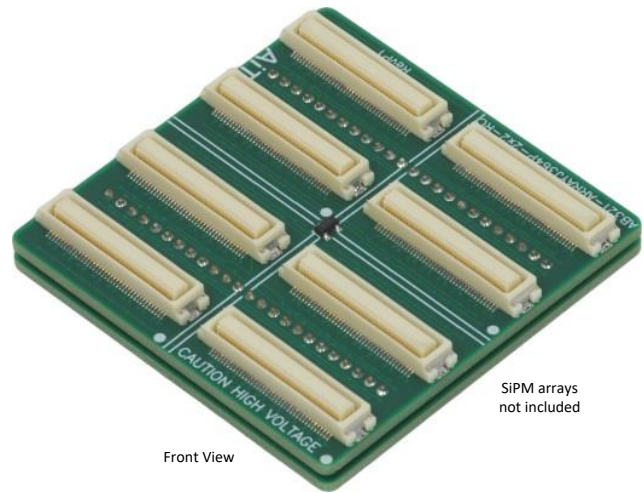

Specifications

Position Signal Outputs

Encoding	Charge division multiplexed to 16 rows and 16 columns
Gain	750Ω transimpedance gain
Output voltage	0 → -1V into 100Ω
Output impedance	100Ω
Output current	50mA maximum

Temperature Sensor

Output voltage	500mV + 10mV per °C
Output current	10mA
Output impedance	100Ω
Accuracy	±0.5°C

Bias Voltage

	+29V typical (refer to SiPM data)
Voltage clamp	47V Zener diode 500mW maximum

Amplifier Voltage (±VA)

	±2.8V → ±5.5V DC maximum
Current	±60mA typical at ±5.0V (I _q , no signal, no load)

Signal Connectors

	Horizontal 40-pin 2-row header with 0.050" pin pitch
Mating assembly	Samtec FFSD-20-D-XX.XX-01-N (XX.XX = length in inches)

Channel Map

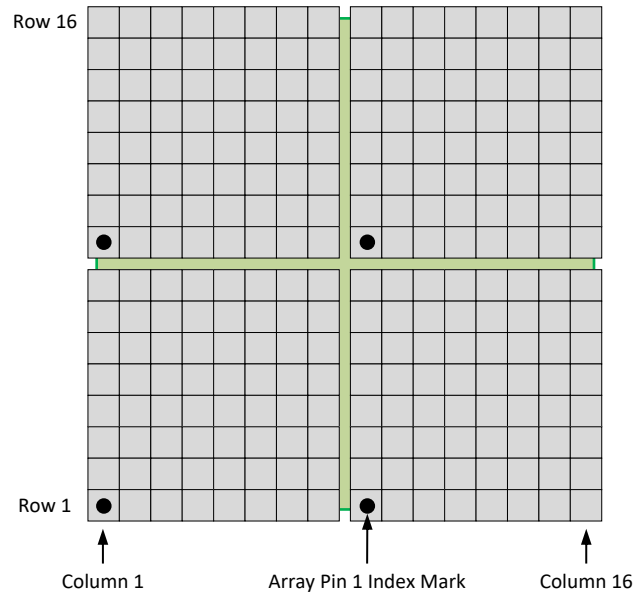

Typical Signals

Source = Laser; Receiver = ABR16, channel 4, minimum gain; Bias = +28V; FFSD cable = 12"

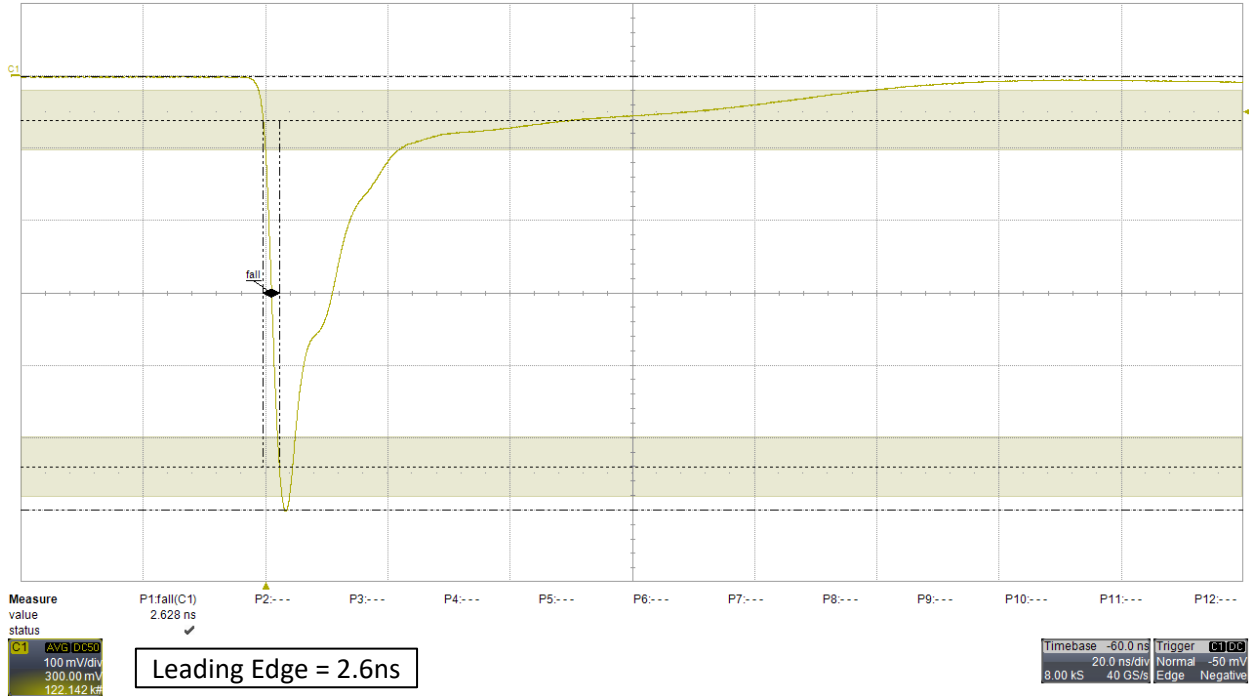

Source = LYSO emission; Receiver = ABR16, channel 4, minimum gain; Bias = +28V; FFSD cable = 12"; persistence display

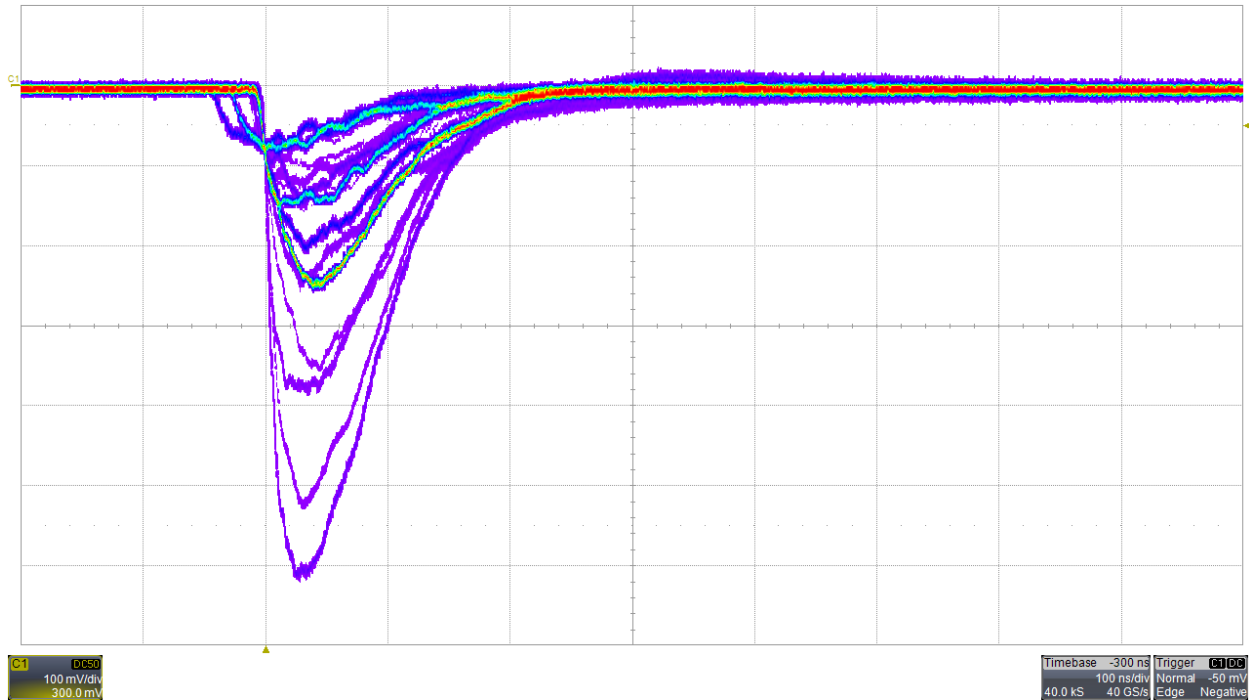

Mechanical

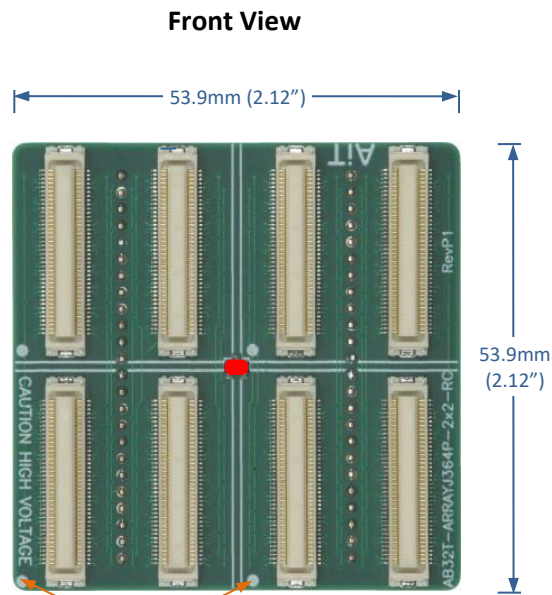

SIPM Array Pin 1 Index Marks

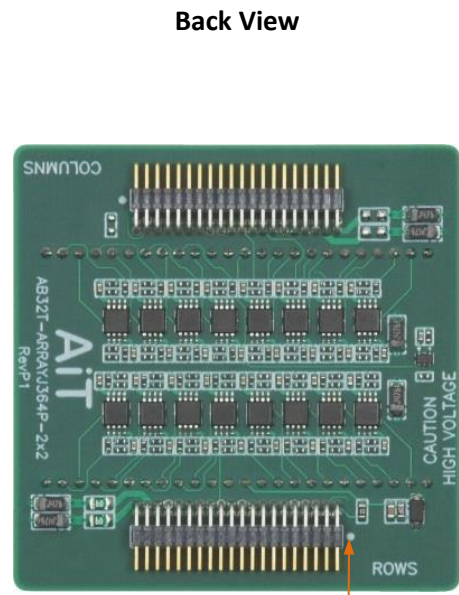

Align pin 1 with red conductor on the Samtec FFSD ribbon cable

● Temperature sensor
Measurement tolerance: ±0.020"

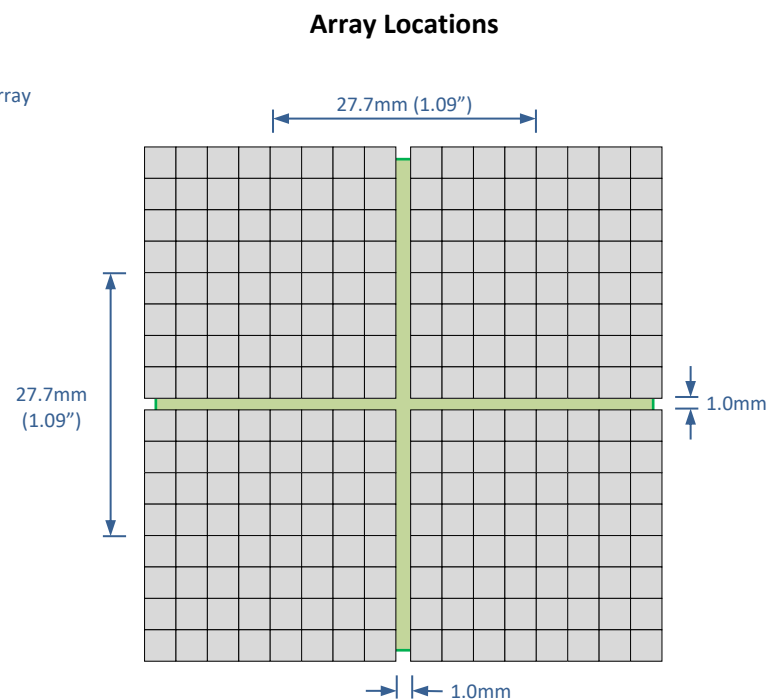
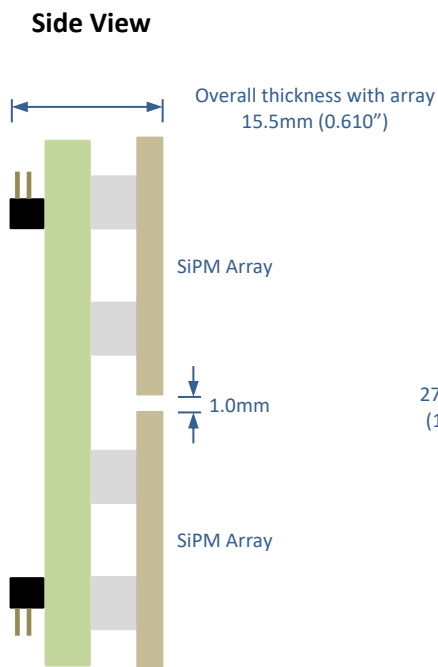

Signal Connectors

ROWS

40-pin 0.050" horizontal header

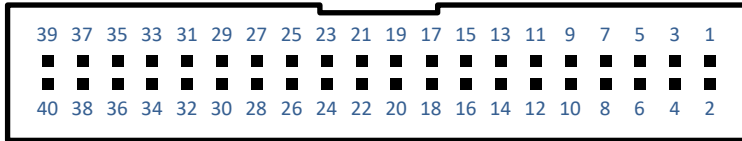

Side View

Pin	Function	Pin	Function
1	+Bias	2	Ground
3	Temperature	4	Ground
5	Row 1	6	Ground
7	Row 2	8	Ground
9	Row 3	10	Ground
11	Row 4	12	Ground
13	Row 5	14	Ground
15	Row 6	16	Ground
17	Row 7	18	Ground
19	Row 8	20	Ground
21	Row 9	22	Ground
23	Row 10	24	Ground
25	Row 11	26	Ground
27	Row 12	28	Ground
29	Row 13	30	Ground
31	Row 14	32	Ground
33	Row 15	34	Ground
35	Row 16	36	Ground
37	-VA	38	Ground
39	+VA	40	Ground

COLUMNS

40-pin 0.050" horizontal header

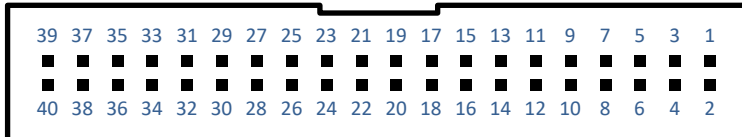

Side View

Pin	Function	Pin	Function
1	*NC (+Bias)	2	Ground
3	Temperature	4	Ground
5	Column 1	6	Ground
7	Column 2	8	Ground
9	Column 3	10	Ground
11	Column 4	12	Ground
13	Column 5	14	Ground
15	Column 6	16	Ground
17	Column 7	18	Ground
19	Column 8	20	Ground
21	Column 9	22	Ground
23	Column 10	24	Ground
25	Column 11	26	Ground
27	Column 12	28	Ground
29	Column 13	30	Ground
31	Column 14	32	Ground
33	Column 15	34	Ground
35	Column 16	36	Ground
37	*NC (-VA)	38	Ground
39	*NC (+VA)	40	Ground

NOTE

* +Bias, +VA, -VA are normally connected to the ROWS connector. These signals are not connected to the COLUMNS connector. Disconnected signals are designated "NC". These signals can be optionally connected to the COLUMNS connector as an assembly variant.

Array Installation Guide

STEP 1

Install the first array by carefully pressing on the array surface above the connectors until the array is firmly seated. An audible “click” will indicate that the connectors are seated.

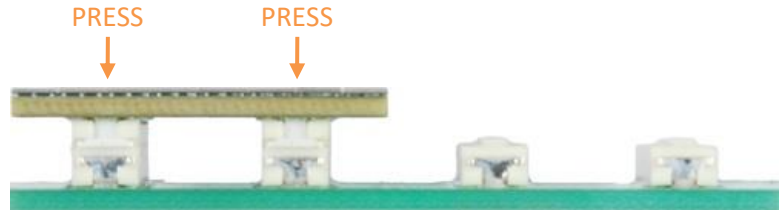

CAUTION: Do not contact the glass surface with any hard object. Any contact will damage the glass.

STEP 2

Attach the second array by carefully pressing above the outer connector until the connector is firmly seated.

Do not press the inner connector first or the glass surfaces may touch and damage the glass.

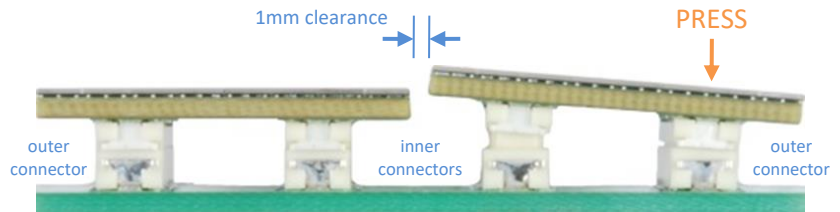

CAUTION: Do not contact the edges of the arrays with each other. Any contact will damage the glass.

STEP 3

Press above the inner connector until the second array is firmly seated.

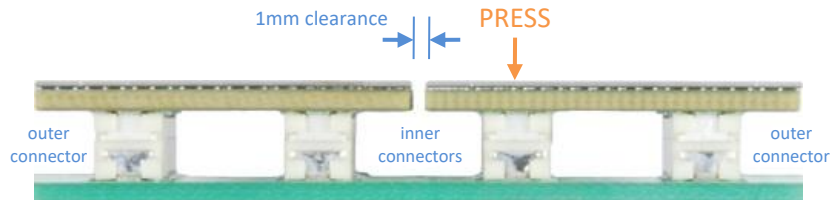

Array Removal

To remove the arrays, reverse the installation procedure. Pull up the connectors labeled **PRESS**. Always pull up the inner connectors first.

WARNING

Never insert the inner connectors first, or remove the outer connectors first. In this case, the small clearance between arrays increases the chance of contacting the surfaces and damaging the glass.

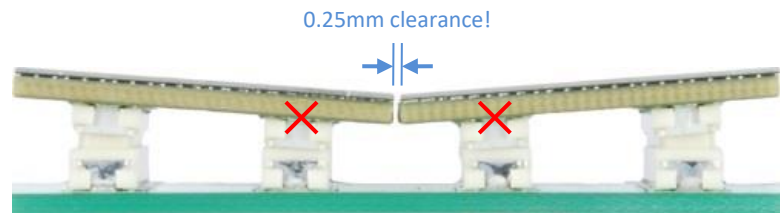

Never insert inner connectors first
Never pull up outer connectors first

16-Channel Active Base Readout Kit

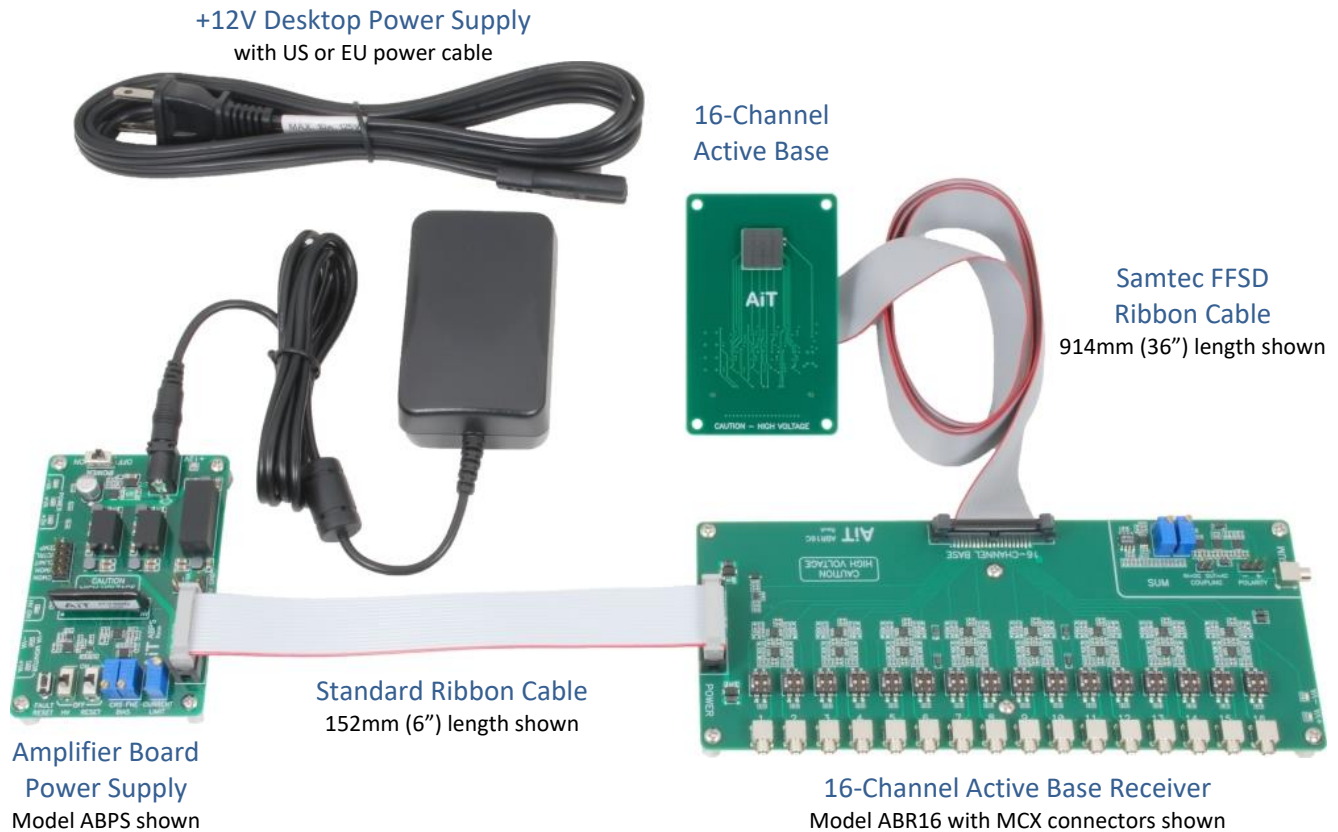

Components

Each component is available separately. Refer to each datasheet for details.

The Active Base includes a 914mm (36") Samtec FFSD micro-pitch ribbon cable.

The Amplifier Board Power Supply includes a 12V desktop power supply and a HV80 bias voltage power supply.

The 16-channel Active Base Receiver includes a 152mm (6") power supply ribbon cable and a breakout board to connect any external power supply.

Safety Information



WARNING – High Voltage

- High voltage may be present during operation
- High voltage stored on capacitors may be present after power is removed
- Improper handling may result in personnel injury or equipment damage

This high-voltage device must be used only by personnel trained and qualified in safe handling, installation, and operation of high-voltage equipment.



CAUTION – Electrostatic Discharge (ESD) Sensitivity

The circuit board can be damaged by electrostatic discharge. Observe precautions for handling electrostatic sensitive devices. Handle only at static-safe workstations.

High-Gain Photodetectors

High-gain photodetectors such as silicon photomultipliers may conduct damaging currents if exposed to high optical signal levels while the bias voltage is applied, or if the bias voltage exceeds the recommended operating range. These devices must be operated only in low-light conditions, and only within the manufacturer's recommended bias voltage range.

Handling and Disassembly

This product may be provided with a protective enclosure. Disassembled enclosure components and circuit boards may contain sharp edges. Take appropriate safety precautions while assembling or disassembling the enclosure and handling disassembled components.

Indoor Use Only

Do not operate this product in a wet or damp environment. Do not operate in an explosive atmosphere.

Use of this product, and AiT Instruments' liability related to use of this product, is further governed by AiT Instruments' standard terms and conditions of sale, which were provided upon purchase of this product.